

SCHALTKREISDIAGRAMM

MODELLE: 320, 420, 420RP, 350M, 420M

MODELLE: TOUCH AND GO

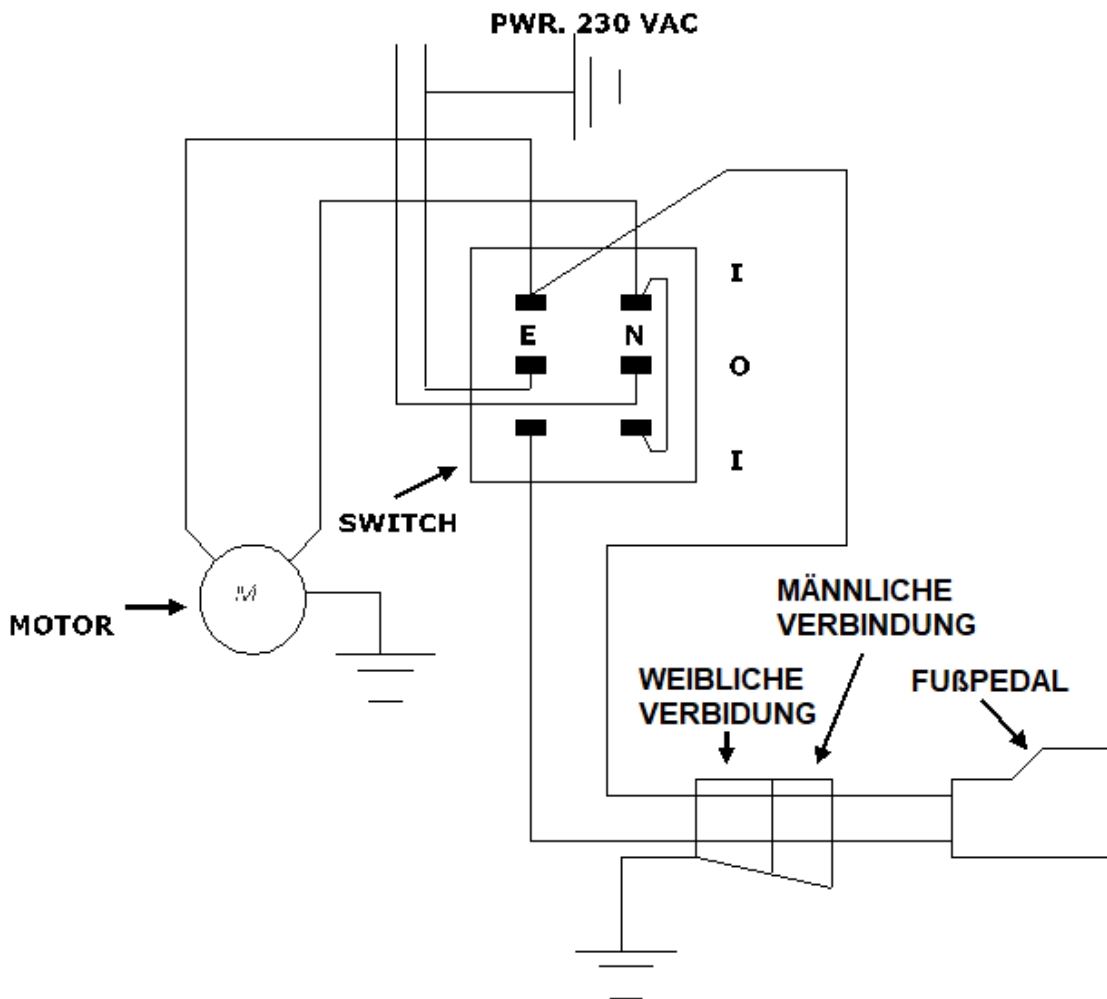
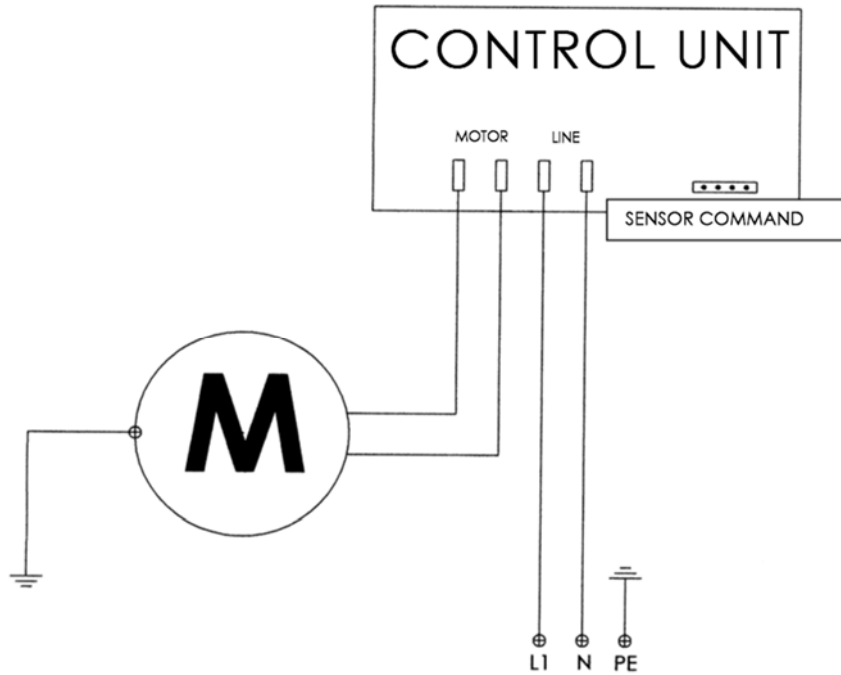

EXPLOSIONSZEICHNUNG

320, 420, 320T.GO, 420T.GO

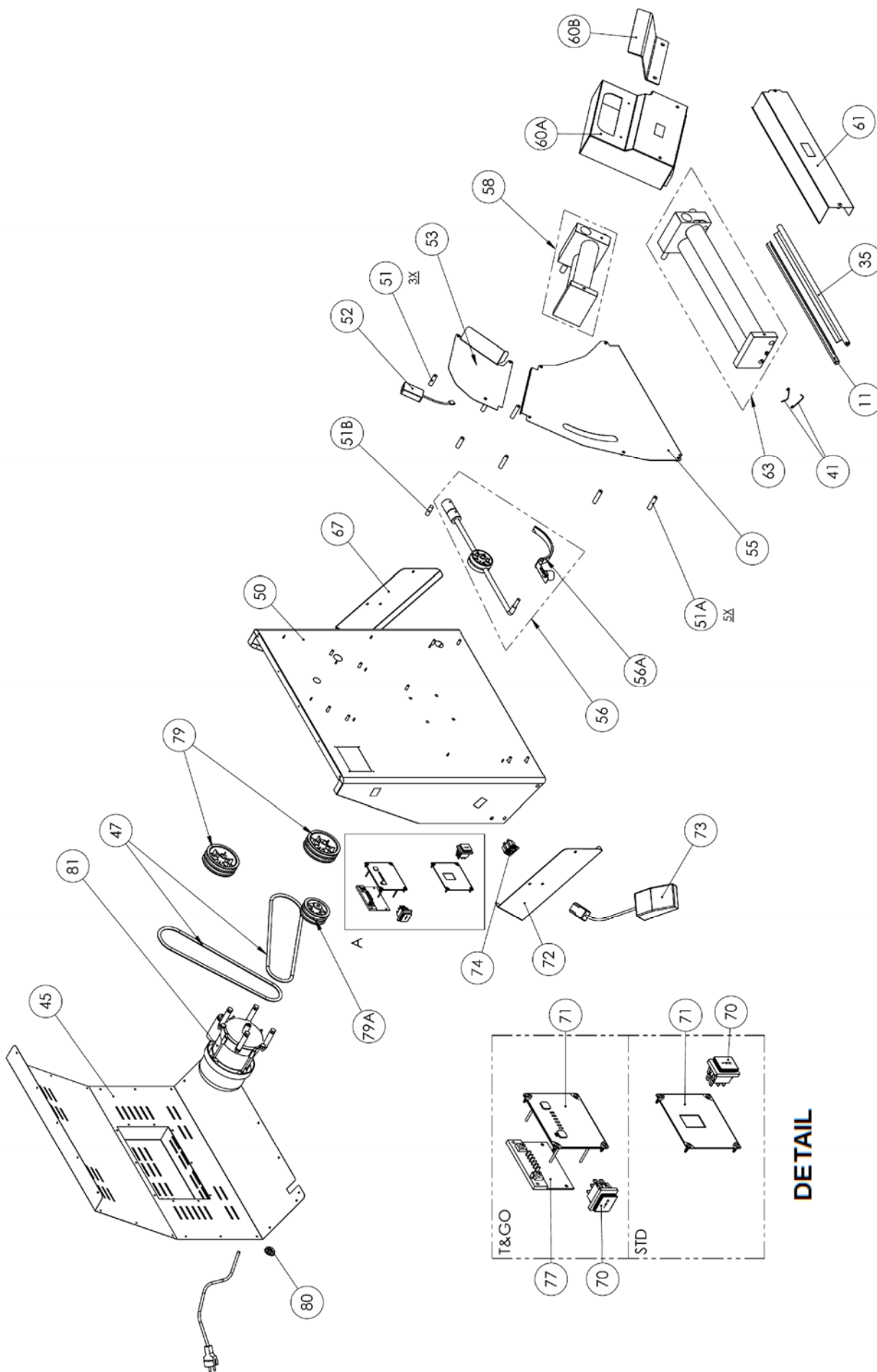

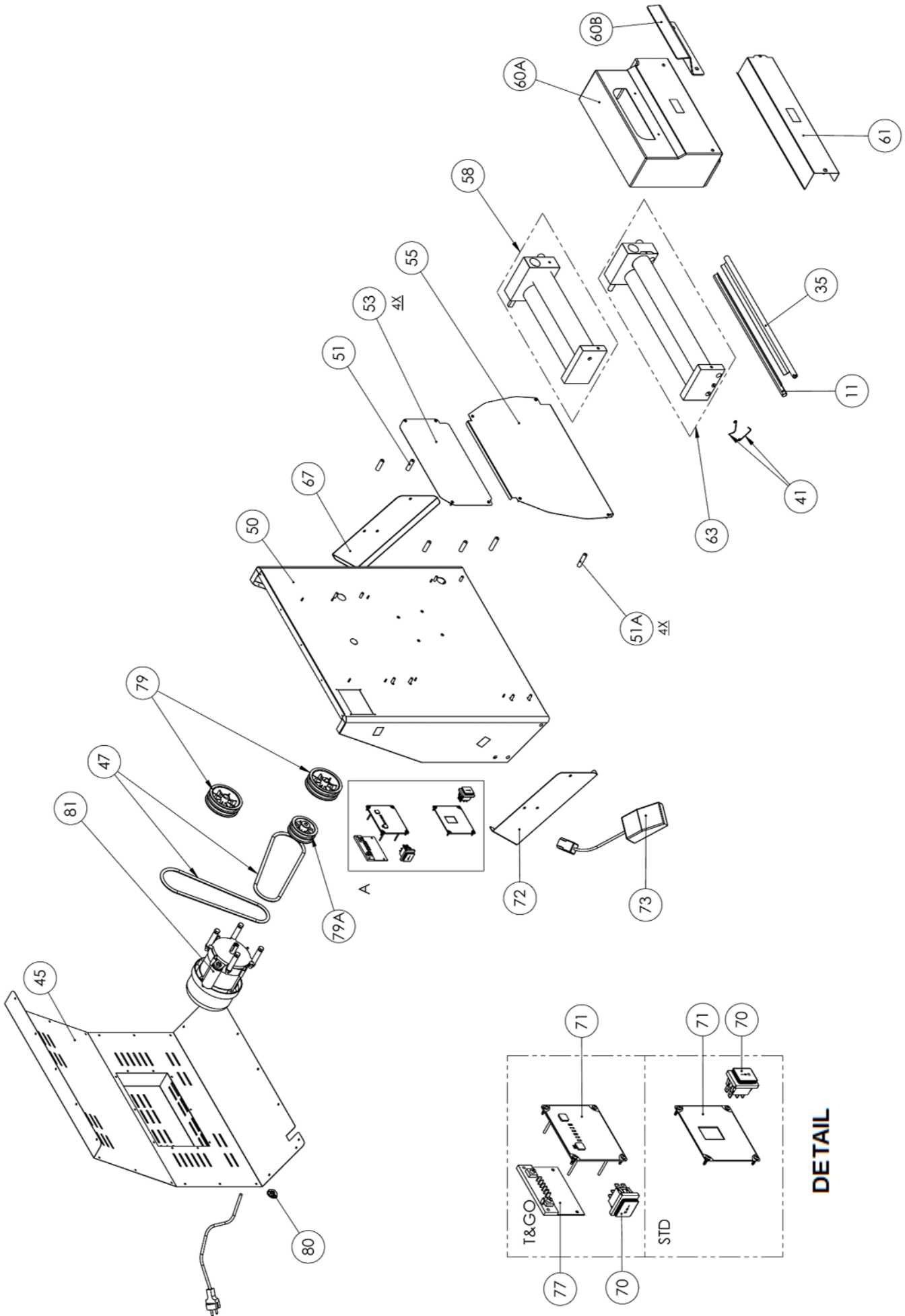

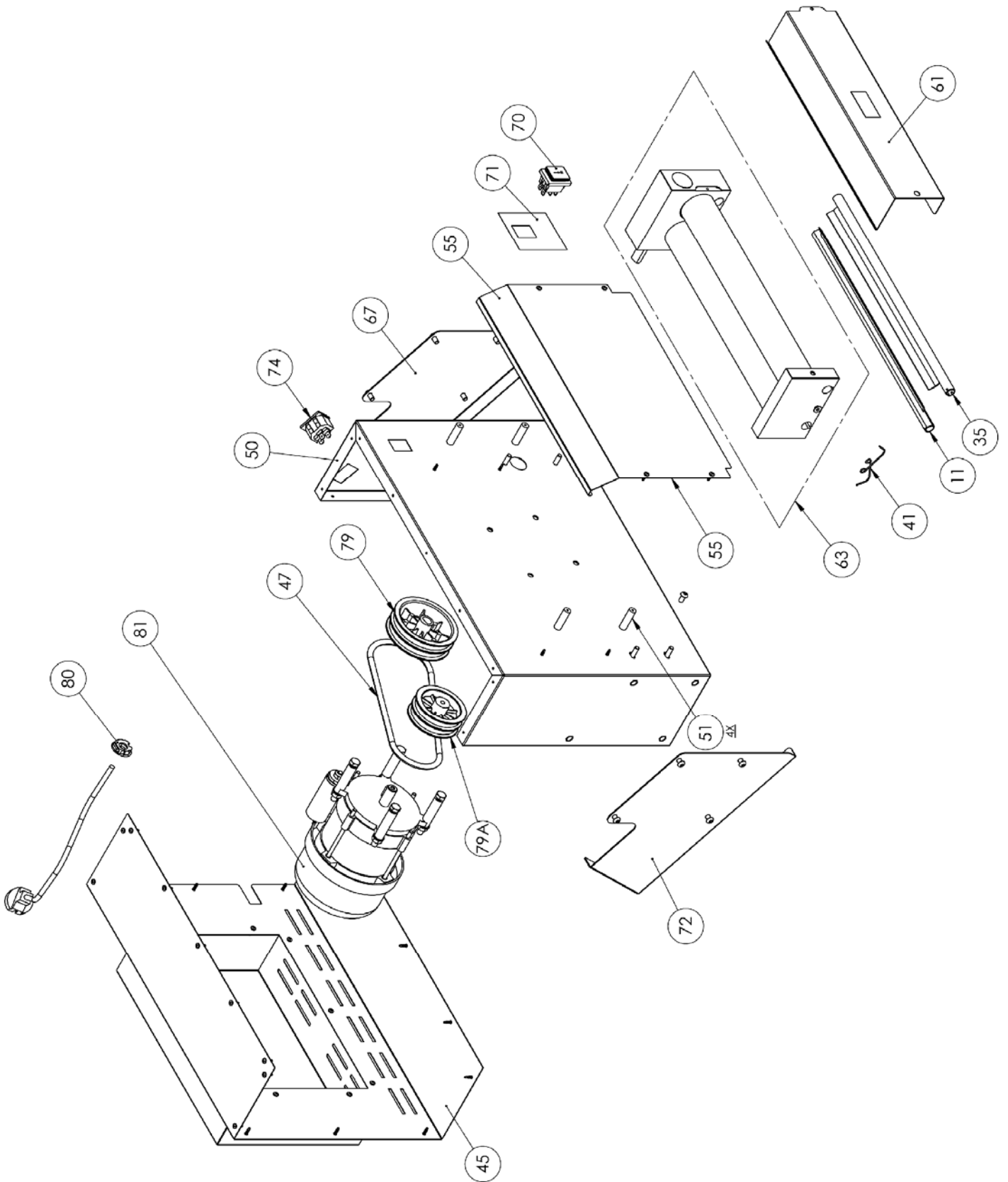

OBERE ROLLENGRUPPE

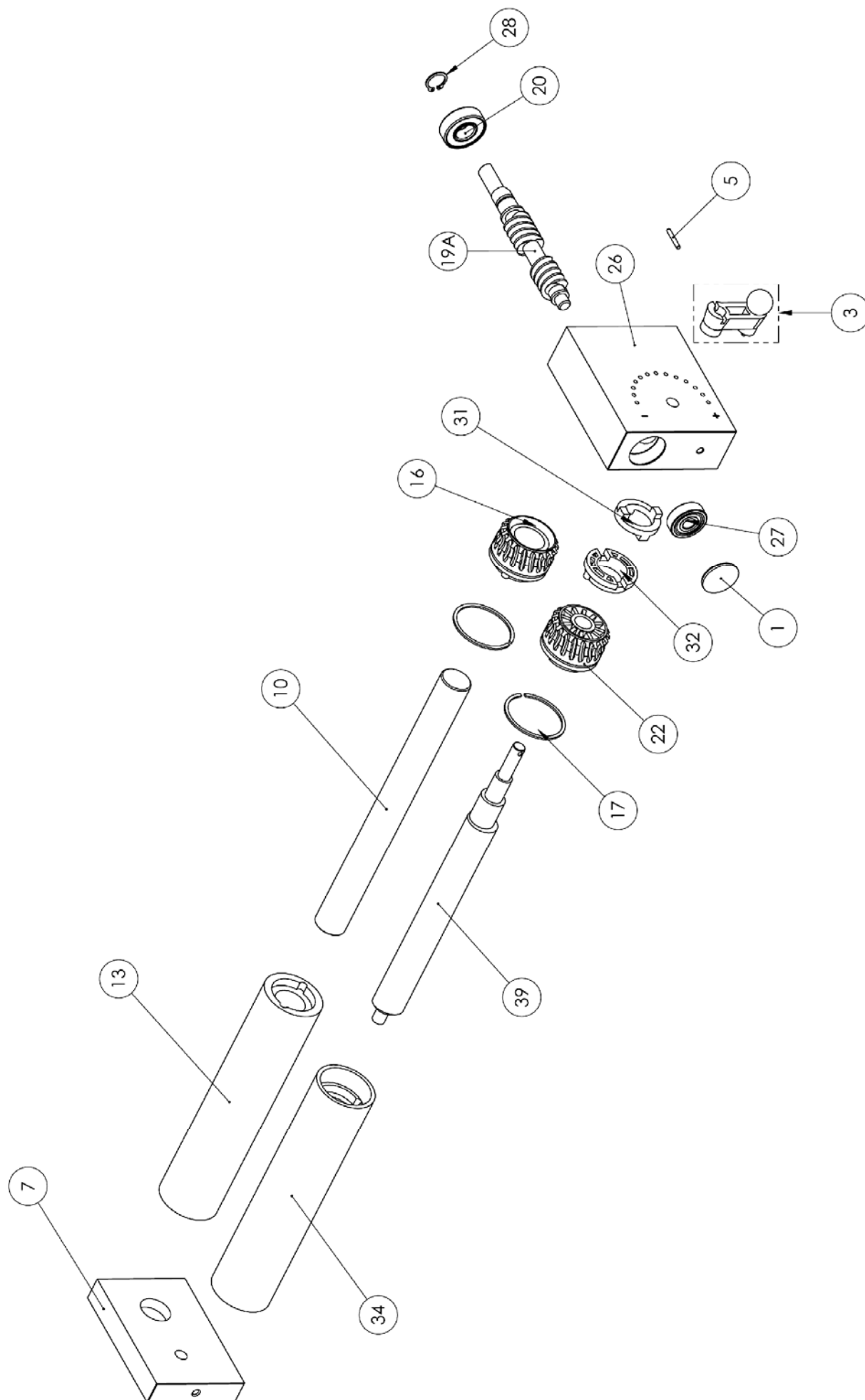

UNTERE ROLLENGRUPPE

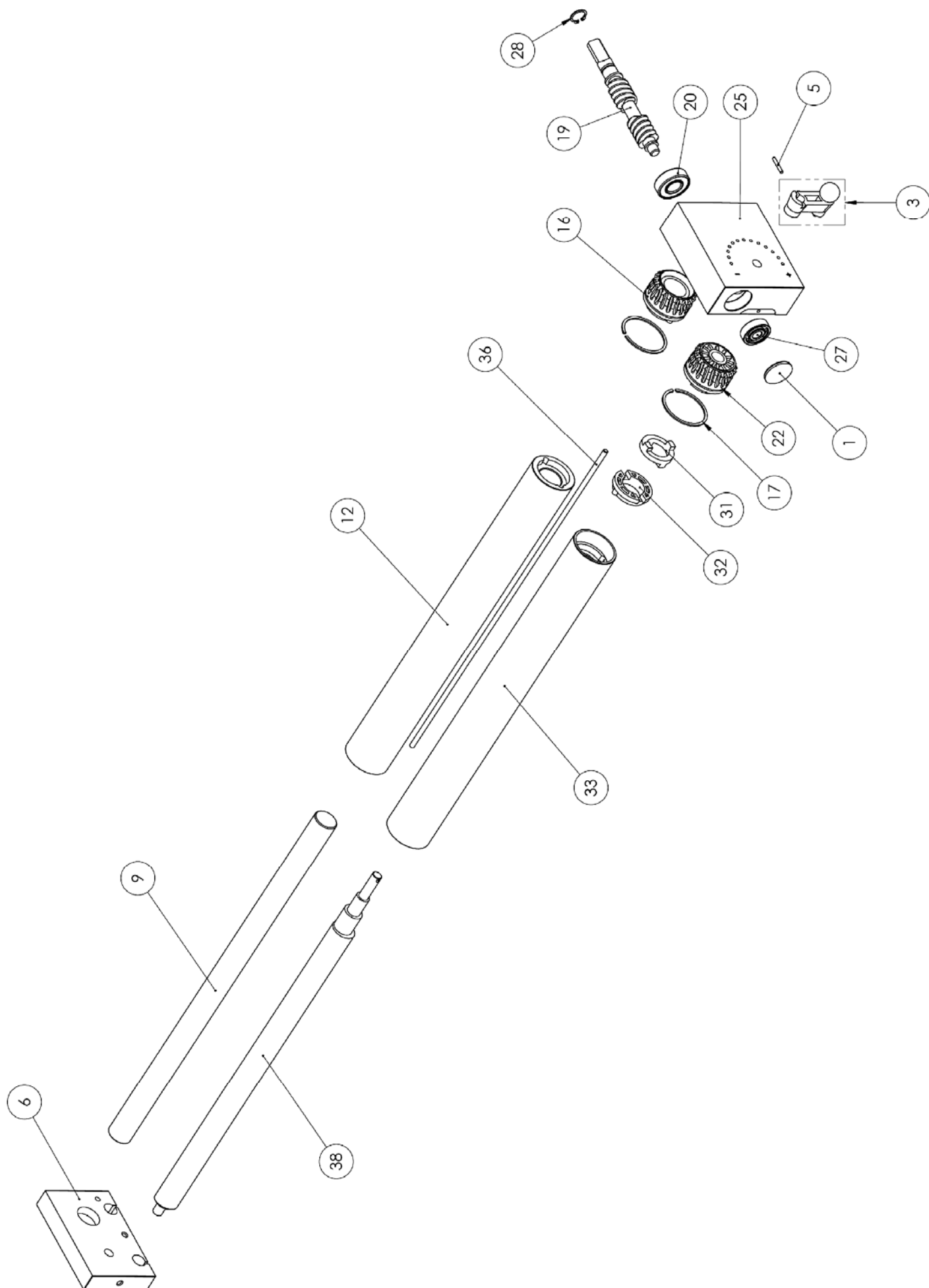

	320	320 T.GO	420	420 T.GO	420 RP	420 RP T.GO	350 M	420 M
1	5T100012							
3	7G010221							
5	5S510006							
6	3S010055							
7	3S010065				3S010066		/	/
9	3A010044	3A010049				3A010065		3A010049
10	3A010034	3A010039		3A010060		/	/	
11	3R020015	3R020016				3R020017		3R020016
12	3R010013	3R010022				3R010017		3R010022
13	3R010014	3R010023		3R010024		/	/	
16	5I200010							
17	5A010001							
19	3V010005							
19A	3V010005				3V010006		/	/
20	5C030000							
22	5I200015							
25	3S010050							
26	3S010060				3S010061		/	/
27	5C030001							
28	5S500010							
31	5G010003							
32	5G010002							
33	3R010052	3R010061				3R010048		3R010061
34	3R010041	3R010046		3R010047		/	/	
35	3R020035	3R020036				3R020037		3R020036
36	6T400700	6T400701				6T400702		6T400701
38	3A010013	3A010018				3A010026		3A010018
39	3A010004	3A010008		3A010009		/	/	
41	5M500005							
47	5C020042	5C020040		5C020041		5C020042	5C020041	
51	3D010007							
51A	3D010002						/	/
51B	3P030003						/	/
52	/	5S010070	/	5S010070	/	5S010070	/	/
56	7B010051	7B010050		/	/	/	/	
56A	4B010051	4B010050		/	/	/	/	
58	7G010256	7G010255		7G010257		/	/	
60A	4P020062	4P020060		4P020061		/		
60B	4P020063							
61	4P020021	4P020020				4P020022		4P020020
63	7G010251	7G010250				7G010252		7G010250
70	5I100001							
73	/	5P020001	/	5P020001	/	5P020001	/	/
74	/	5P200001	/	5P200001	/	5P200001	/	/
77	/	5C150030	/	5C150030	/	5C150030	/	/
79	5P040020							
79A	5P040015							
80	5P100015							
81	5M020015							